

A capacitor-free driving stage for light emitting diodes

F.A. Himmelstoss¹, and M. Windisch¹

¹ Faculty of Electronic Engineering & Entrepreneurship
 University of Applied Sciences Technikum Wien
 Hoechstaedtplatz 6, 1200 Wien (Austria)

e-mail: felix.himmelstoss@technikum-wien.at, michael.windisch@technikum-wien.at

Abstract. Electrolytic capacitors have the disadvantage of pronounced aging. Non-electrolytic capacitors are therefore used in applications where long-life is important. In this paper we present a driving stage for LEDs without any capacitive elements. The basic topology is a Buck converter with one coil, one active, and one passive switch. Instead of the output capacitor, series connections of one or more LEDs and an active switch are connected. An additional diode is connected between the output and the input to achieve a current path, when all LED-paths are off. A nonlinear hysteresis controller is used to achieve a robust control. A system with three switchable LED-strings is analyzed. Design hints are given and the function is proved with the help of LTSpice simulations. The system can be used for lighting purposes with the possibility to change the chrominance. The potentiality to transmit data is also treated.

Key words. LED, power converter, current control, two-level controller, capacitor-free.

1. Introduction

The converter (Fig. 1) consists of the main switch S_M , the free-wheeling diode D_F and the inductor L . The load consists of series connections of the light emitting diodes and active switches S_A , S_B , and S_C which are connected in parallel. To avoid overvoltage, when all switches of the load are off, a diode D_R is connected between the output and the input. In this case the inductor feeds energy back into the source. To stop the reverse flow of energy, the electronic switch S_P can be turned on. Now the current of the coil can free-wheel through this switch S_P and the free-wheeling diode D_F . This switch can be also used when the load shall be shunted e.g. for dimming or for sending information.

The most interesting aspect of the here treated system is the fact that no capacitive elements are necessary. Electrolyte capacitors are elements which are aging especially at higher temperatures and fail. Another advantage of this converter compared to other LED drivers treated in the literature (c.f. especially the overview given in [1]) is that no capacitor is mounted in parallel to the load. LEDs change their characteristics with the temperature and controlling the output voltage can lead to overload and to the destruction of the LEDs. Therefore,

controlling only the current leads to a reliable system. Other converters which have a current output are treated in [2]. The usage of light-emitting diodes is not only illumination, but also disinfection [3], and medical treatments e.g. [4]. These papers cite other interesting literature. Valuable textbooks for Power Electronics are e.g. [5-7]. About the aging of capacitors refer to [8]. [9] is a study of the efficiency of pulsed UV-light for disinfection. In [10] LEDs are used for a high efficient street lighting without electrolytic capacitors. Especially in street lighting the devices are exposed to high thermal stress. A study of predictive control for a capacitor-less LED driver can be found in [11]. In this case no capacitor is used parallel to the load, but capacitors are necessary in the used PFC.

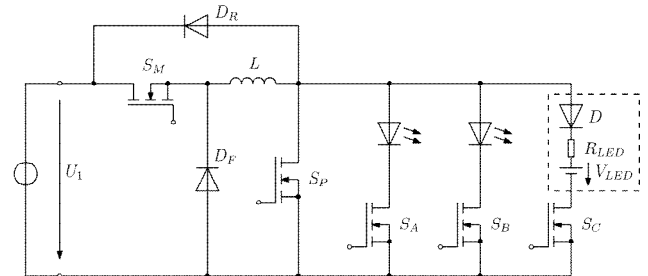

Fig. 1. Capacitor free LED driver.

2. Linear model

The input voltage must be higher than the necessary load voltage

$$U_1 > V_{LED} + R_{LED} I_L \quad (1)$$

The linear model for one string can be written as

$$\frac{d}{dt} i_L = \frac{1}{L} \{u_1 - R_{LED} i_L - V_{LED}\} \quad (2)$$

for mode M1 (main switch is on) and

$$\frac{d}{dt} i_L = \frac{1}{L} \{-R_{LED} i_L - V_{LED}\} \quad (3)$$

for M2 (main switch is off, the free-wheeling diode is conducting).

Combining these two equations by weighting them with the time they are valid leads to

$$\frac{d}{dt} i_L = \frac{1}{L} \{u_1 \cdot d - R_{LED} i_L - V_{LED}\} \quad (4)$$

This is a nonlinear equation. Linearization about the working point leads to the small signal equation

$$\frac{d}{dt} \hat{i}_L = \frac{1}{L} \left\{ u_1 \cdot \hat{d} - R_{LED} \cdot \hat{i}_L \right\} \quad (5)$$

and to the connection between the working point values according to

$$U_{10} D_0 - R_{LED} I_{L0} - V_{LED} = 0. \quad (6)$$

Fig. 2 shows the signal flow graph in the Laplace domain. The Laplace variables describe the disturbances around the working point. The actual value is always the working point value added by the disturbance value.

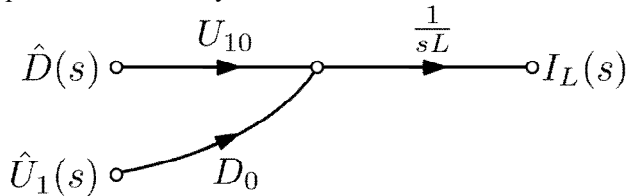

Fig. 2. Signal flow graph for a system with only one load string.

The transfer function of the plant can now be given according to

$$P(s) = \frac{U_{10}}{sL}. \quad (7)$$

The influence of the disturbance (changes of the input voltage) is given by

$$P(s) = \frac{D_0}{sL}. \quad (8)$$

The small signal system looks very simple, but the system is always changing between the different operation modes; also the load LED-strings have different parameters. Furthermore, the system is an integral one, so a simple P-controller can be used. But looking at the disturbance transfer function, a steady state error caused by the changes of the input voltage occurs! Therefore, it is much better to use a nonlinear controller.

3. Nonlinear control

The best way to control this converter is by using a two-level controller or a hysteresis controller. This leads to a very robust control in all switching cases and enables an easy start-up without overshoot. First we calculate the switching frequency of the controller for the case when one load stage is turned on (Fig. 3 and 4). To simplify the calculation, the parasitic elements of the converter are omitted.

A. Load operation

During the on-time of the active switch, the voltage across the inductor is equal to the input voltage reduced by the voltage across the load. The load is modelled by a fix voltage V_{LED} and a resistive component (the differential resistor of the light emitting diode or diodes) R_{LED} . The current now increases by ΔI . During the off-time of the switch S_M , the free-wheeling diode D_F is conducting and the voltage across the coil is now the negative voltage across the load, and the current decreases according to the hysteresis again by ΔI . The charge balance (Fig 3, left) across the inductor in steady-state is therefore

$$(U_1 - V_{LED} - R_{LED} I_{L0}) \cdot T_{on} = | -V_{LED} - R_{LED} I_{L0} | \cdot T_{off}. \quad (9)$$

The on- and off-times and therefore the switching period depends on the chosen current ripple which is fixed by the hysteresis of the controller. The on-time and the off-time can therefore be calculated according to

$$T_{on} = \frac{\Delta I \cdot L}{U_1 - V_{LED} - R_{LED} I_{L0}} \quad (10)$$

$$T_{off} = \frac{\Delta I \cdot L}{V_{LED} + R_{LED} I_{L0}}. \quad (11)$$

The switching period is the sum of the on- and off-times

$$T = \Delta I \cdot L \frac{U_1}{(U_1 - V_{LED} - R_{LED} I_{L0})(V_{LED} + R_{LED} I_{L0})}. \quad (12)$$

The current produces the voltage U_2 across the load and so one can write for the switching frequency

$$f = \frac{(U_1 - V_{LED} - R_{LED} I_{L0})(V_{LED} + R_{LED} I_{L0})}{\Delta I \cdot L \cdot U_1} = \frac{U_2(U_1 - U_2)}{\Delta I \cdot L \cdot U_1} \quad (13)$$

The frequency changes when the input voltage changes and also when the load changes (this happens, when the desired current is changed and also when the load itself changes e.g. by the change of the temperature). Another advantage is that tolerances of the load do not matter either, only the frequency of the converter changes.

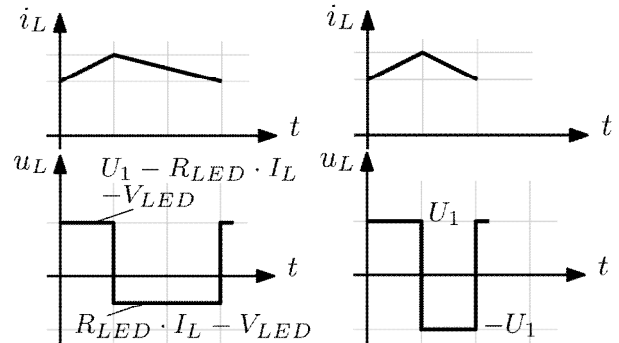

Fig. 3. Current through and voltage across the inductor: load operation (left), recuperation operation (right).

Fig. 3 shows the current through and the voltage across the coil for normal and for recuperation operation. From Fig. 1 one can see that two other modes are possible.

B. Recuperation operation

When the load is turned off and the main switch S_M and the parallel switch S_P are working together and when both these switches turn off, the free-wheeling D_F and the recuperation diode D_R turn on, the voltage-time balance across the coil can be written as

$$U_1 \cdot T_{on} = | -U_1 | \cdot T_{off}. \quad (14)$$

The on- and off-times are now equal

$$T_{on} = T_{off} = \frac{\Delta I \cdot L}{U_1} \quad (15)$$

and so the frequency adjusts to

$$f = \frac{U_1}{2\Delta I \cdot L}. \quad (16)$$

The frequency now depends only on the input voltage (the hysteresis of the converter is constant). Fig. 3 shows

on the right side the current through and the voltage across the coil for recuperation operation.

C. Idling operation

The third possibility is the idling mode. Here again the main switch S_M is clocked and the parallel switch S_P is always on. When the main switch is on, the input voltage is across the coil. When the main switch turns off, the free-wheeling diode D_F turns on. Now only the forward voltage of the diode U_D is across the inductor and the current decreases. The diode is a Schottky diode with a relative low forward voltage. So the off-time is large and the occurring switching frequency is low. For the on- and off-times one can write

$$T_{on} = \frac{\Delta I \cdot L}{U_1} \quad (17)$$

$$T_{off} = \frac{\Delta I \cdot L}{U_D} \quad (18)$$

The frequency in the idling mode is therefore

$$f = \frac{U_1 U_D}{\Delta I \cdot L (U_1 + U_D)} \approx \frac{U_D}{\Delta I \cdot L} \quad (19)$$

Fig. 4 sketches the current through and the voltage across the coil for the idling operation.

The minimal frequency of the converter will occur in the idling mode and the maximum frequency occurs, when the converter works in the recuperation mode, when energy is taken from the source during the on-time of the switch and fed back again when it is off. The switching frequency is indirect proportional to the inductor value.

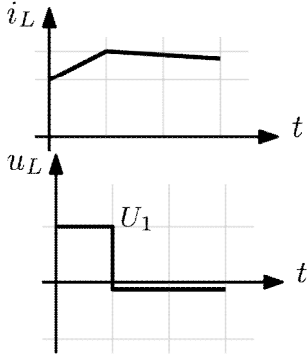

Fig. 4. Current through and voltage across the inductor in the idling operation.

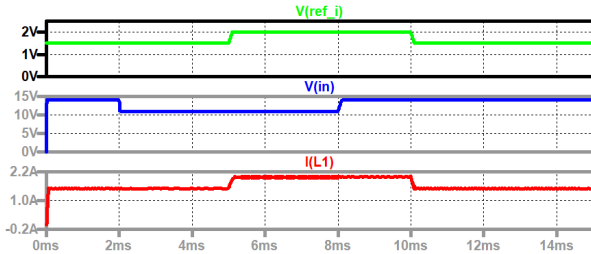

Fig. 5. Start-up, reference and input voltage steps (up to down): reference value (green), input voltage (blue), current through the coil.

Fig. 5 shows the current through the coil, the reference value, and the input voltage. The load is changed with cycles of 50 kHz. One can see the step-up, a fast step-down of the input voltage after 2 ms, a change of the reference value (1V reference equals 1 A current through

the inductor) at 5 ms and at 10 ms, and at 8 ms the input voltage increases again to 14 V.

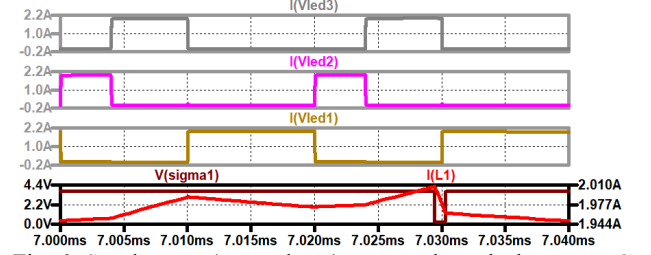

Fig. 6. Steady-state (up to down) current through the stages C (grey), B (violet), A (brown); current through the coil (red), output of the controller (black): low input voltage.

Figs. 6 & 7 show the currents through the three stages, the current through the inductor and the output signal of the controller which supplies the driver of the main switch. In Fig. 6 the voltage is low, therefore the main switch is on during most of the period, in Fig. 7 the voltage is high and therefore the controller generates a higher switching frequency.

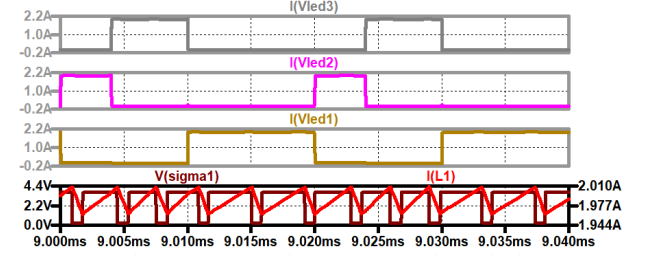

Fig. 7. Steady-state (up to down) current through the stages C (grey), B (violet), A (brown); current through the coil (red), output of the controller (black): high input voltage.

D. Dimension and simulation hints

The inductor can be calculated from (16) for a chosen current ripple and for a desired maximum switching frequency. All simulations were done by LTSpice with input voltage between 9 V and 14 V, an inductor of 200 μ , strings are modeled by (V_{LED} , R_{LED}) A: 5.5 V, 2.5 Ω , B: 6 V, 2 Ω , C: 4 V, 2.5 Ω .

4. Inrush-current and start-up

The inrush-current and the start-up of a converter must be studied carefully, because it can lead to saturation of the coil and to large currents through the devices.

In our converter no inrush current occurs, because the main switch is mounted into the power flow path. Power is only sourced from the input, when S_M is turned on. Furthermore, no capacitor has to be charged when the converter is started (e.g. in a normal Buck converter the output capacitor must be charged slowly by increasing the duty cycle or by the bang-bang controller).

The converter is started by turning on the main switch S_M and current starts to flow. When a load is connected the maximal current

$$I_{L,max} = I_{L0} + \frac{\Delta I}{2} \quad (20)$$

is reached within

$$T_{on} = \frac{I_{L0} + \Delta I / 2}{U_1 - V_{LED} - R_{LED} I_{L0}} \quad (21)$$

when we assume that the mean value lays in the middle of the hysteresis.

Now the switch turns off and the two-level controller works in the steady state.

A faster on-time is reached, when the main switch and the parallel switch are turned on at the beginning

$$T_{on} = \frac{(I_{L0} + \Delta I / 2) \cdot L}{U_1} \quad (22)$$

After this time interval the controller works in the steady state.

Fig. 8 shows a start-up of the converter. The parallel switch is turned on (control signal sigma2), after 25 μs the start signal enables the converter (signal start) and the two-level controller starts and controls the main switch (signal sigma1). The current increases linearly until it reaches the maximum value. Afterwards the converter is in the idling mode, until the parallel switch is turned off. Now the normal operation can begin.

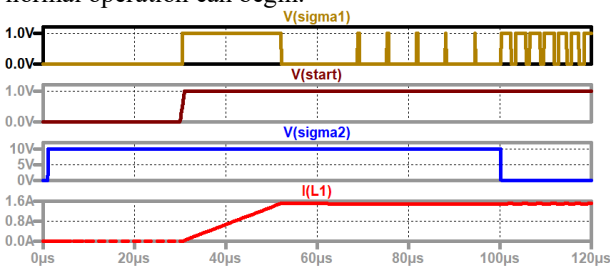

Fig. 8. Start up (up to down): control signal of the main switch SM (brown), start signal enable (black), control signal of the parallel switch SP (blue), current through the coil (red).

Using a two-level controller leads to a fast, very stable and robust system. No special account has to be taken during start-up (which is necessary when a linear control concept would be used). Changes of the load or different switching patterns lead to no pronounced transients.

5. Dimming of the light

To change the intensity of the emitted light two possibilities are feasible: changing the mean value of the current through the inductor (Fig. 9), or turning on the parallel switch and going into the idling mode (Fig. 10). In this second concept the current through the load is of the same value as before, when the parallel switch is turned on, and when S_P is turned off again. The easiest way to realize this is by interrupting the light of one cycle or to shorten the time pulses for each load string and include an idling operation before the next cycle begins. The advantage of this concept is that the color temperature does not change (some light emitting devices change the color a bit, when the supply current changes).

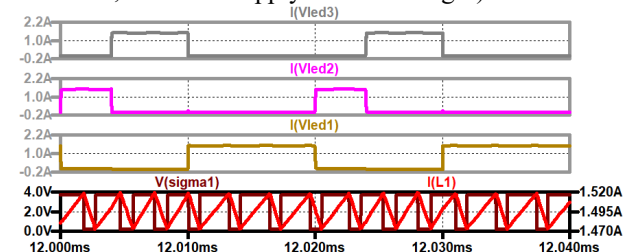

Fig. 9. Dimming method 1, steady-state (up to down): current through the stages C (grey), B (violet), A (brown); current through the coil (red), output of the controller (black).

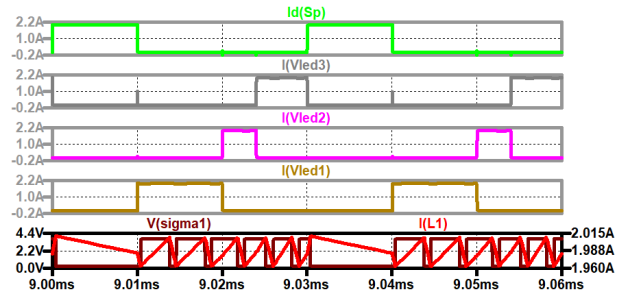

Fig. 10. Dimming method 2, steady-state (up to down): current through the parallel switch (green), current through the stages C (grey), B (violet), A (brown); current through the coil (red), output of the controller (black).

Figs. (9 & 10) show the two dimming methods in the steady-state. For method 1 the currents through the load stages and the current through the inductor are shown. The output signal of the two-level controller is also depicted.

For the second method the current through the parallel switch S_P is also shown. The current is always in a small band around the desired value. Increasing the inductor or an enlargement of the hysteresis would reduce the switching frequency.

Normally the loads differ in the various stages. When a load switch is turned off, another one should have been turned on immediately before this event. When no load switch is on and the parallel switch is off too, the current can fly back to the input source via the recuperation diode D_R and the free-wheeling diode D_F . With this recuperation diode reliability of operation is always given.

6. Application of the system

A. Changing the chrominance and pulsed light sources

With three strings of blue, red and green LEDs the chrominance can be adjusted by changing the on-times of the different strings.

B. Pulsed light sources for disinfection

Especially for disinfection pulsed LED devices are necessary [3, 9]. Pulsed UVC light is more efficient than a continuous one.

C. Sending additional information

Another interesting aspect is that one can code information into the transmitted light [12]. At the receiver side, photodiodes for the three colors are necessary to separate the different information streams (or optical filters).

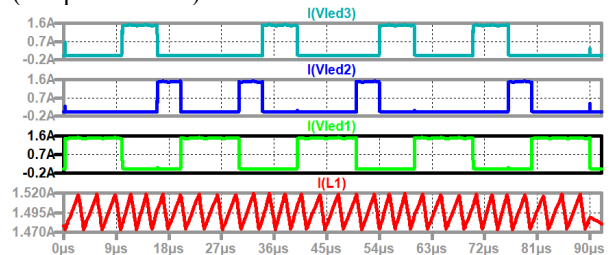

Fig. 11. Transmitting information 1001 (up to down): current through the LED-strings C (grey), B (blue), C (green), current ripple of the coil (red).

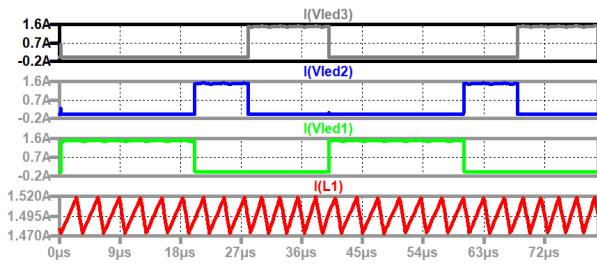

Fig. 12. Information coding current through the LED-strings C (grey), B (blue), C (green), current ripple of the coil (red).

One easy to realize concept is that one stage is the reference signal and the information is coded into the sequence of the two others. As an example we use stage A as the reference clock and we code a logic zero by turning stage B before turning on stage C. When a logic one shall be coded, we turn on stage C before stage B. The information 1001 would therefore be sent as ACB, ABC, ABC, ACB. This is depicted in Fig. 11.

Synchronizing pulses (start bit) can be achieved by turning on SP for e.g. one period. This will not influence the brightness, as the switching frequency is high to avoid perceptible flicker. The information rate is naturally small and no bidirectional information flow is possible, but it can be used for sending state information e.g. for energy optimizing or to transmit information from a sensor like temperature or humidity.

Another way is to turn-on one string longer e.g. two times longer and do not turn on this string during the next cycle. The other strings, which have reduced on-times in the first cycle, have longer on-times in the second one, so the mean value is equal when calculated over two cycles (Fig. 12). In the next cycles other combinations are chosen. More complex patterns can be used.

The parasitic inductances of the LED-strings lead to overvoltage across the string-switches S_A , S_B , S_C when the strings are mechanically far away from the driver. In this case small RC-snubbers have to be used in parallel to the string-switches.

7. Conclusion

The converter has several interesting points:

- No capacitor is necessary in the power stage (except for a snubber network which can be necessary in some cases, or a small input capacitor to avoid an overvoltage, due to the parasitic inductance of the connection wires to the input source)
- Low count of devices, therefore high reliability and efficiency
- A simple two level-controller leads to a very stable and robust system
- No inrush-current
- Easy soft-start
- Easy dimming
- Possibility to change the chrominance of the produced light
- High frequency, therefore no flicker
- Possibility to code information
- Common input and output

The converter can be used especially for lighting applications in combination with small DC micro-grids supplied with photovoltaic, fuel cells, small wind or water turbines and batteries and super-caps as energy storage devices. Additionally, it can be used also for UVC-LEDs in disinfection systems and to drive IR-LEDs for thermal treatment and punctual heating.

The complete system (without the coil and naturally the LED-strings) can be implemented into an integrated circuit. The possibility to code information can be interesting to send state informations of the system without using RF (radio frequency) devices. The optical receiver can be easily realized. So the lighting system can be included into a distributed system (e.g. street lighting in a village or city).

References

- [1] F. Bento, F. and A. J. M. Cardoso, "Comprehensive survey and critical evaluation of the performance of state-of-the-art LED drivers for lighting systems", Chinese Journal of Electrical Engineering (2021), vol. 7, no. 2, pp. 21-36.
- [2] F. A. Himmelstoss, "Third order converters with current output for driving LEDs", WSEAS Transactions on Power Systems (2022), Vol. 17, pp. 402-409, E-ISSN: 2224-350X, Print ISSN: 1790-5060 DOI: 10.37394/232016.2022.17.40
- [3] F. Himmelstoss and K. Edelmoser, "Liquid and surface disinfection with pulsed UVC LEDs", 2. Ahi Evran International Conference on Scientific Research. Kirshehir, Turkey, 21.-23. October 2022, Vol. 4, pp. 654-664, ISBN - 978-625-8246-64-3.
- [4] F. A. Himmelstoss and K. H. Edelmoser, "Thermo-Puncture Devices – Mechanical and Electrical Concepts", Power electronics and Motion Control PEMC, Varna Sept. 26.-30. 2016, pp. 221-226, ISBN 978-1-5090-1797-3.
- [5] F. Zach, Power Electronics, in German: Leistungselektronik, Springer, Frankfurt, 6th ed., 2022.
- [6] Y. Rozanov, S. Ryvkin, E. Chaplygin and P. Voronin, Power Electronics Basics, CRC Press, 2016.
- [7] N. Mohan, T. Undeland and W. Robbins, Power Electronics, Converters, Applications and Design, 3rd ed. W. P. John Wiley & Sons, New York, 2003.
- [8] G. Zhang, W. Chen, S. S. Yu, A. E. Aroudi and Y. Zhang, "Replacing All ECs with NECs in Step-Up Converters—A Systematic Approach", IEEE Transactions on Power Electronics, vol. 37, no. 1, pp. 31-36, Jan. 2022.
- [9] V.M. Gomez-Lopez, et. al., Pulsed light for food decontamination: a review. Trends in Food Science & Technology (2007), 18, pp. 464-473.
- [10] M. Arias, D. G. Lamar, J. Sebastian, D. Balocco and A. A. Diallo, "High-Efficiency LED Driver Without Electrolytic Capacitor for Street Lighting," in IEEE Transactions on Industry Applications, vol. 49, no. 1, pp. 127-137, Jan.-Feb. 2013, doi: 10.1109/TIA.2012.2227644.
- [11] Z.Liao, D. Qiu, s. Zhang, C. Cao, "New electrolytic capacitor-less LED driver based on model predictive control," Optic – International Journal for light and Electron Optics 199, 2019.
- [12] K. H. Edelmoser and F. A. Himmelstoss, "High Dynamic Current Source for LED Light and Data Transmission Applications", Power Conversion and Intelligent Motion PCIM Europe 2016, Nuernberg, pp. 1741-1748, ISBN 978-3-8007-4186-1.

Appendix: Realization of the controller

A simple way to realize the controller is by using a comparator with hysteresis. The hysteresis can be adjusted by the resistors R1 and R2. The comparator is supplied by plus/minus 5 V (it is also possible in our case to use a single supplied comparator; if a negative voltage is necessary, it could be realized by a small switched-capacitor converter, because only small power is needed). The current through the inductor, the control variable, has to be measured. In the simulation this is done with the

voltage source V3 which controls the current-controlled voltage source H1, which produces a voltage signal representing the current through the load “I_mes” which is connected to the controller. The reference value is generated by the voltage source V4. The circuit is enabled by the signal “start” and the AND-gate A1. The voltage-controlled voltage source E1 realizes the floating driver for the main switch. (Using a p-channel MOSFET would simplify the driver for S_M.) The load strings are modelled by a diode, a voltage source, and a resistor for each string.

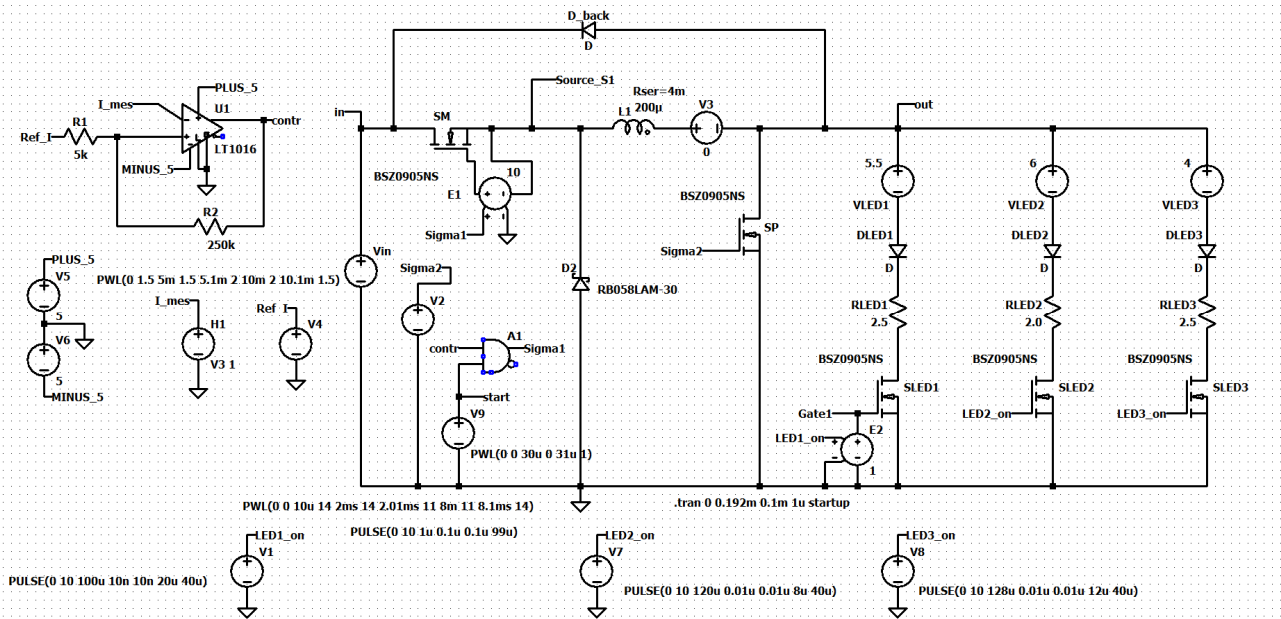

Fig. A. Control of the converter and used simulation circuit.