

# Electrical design of a smart control and monitoring system for small horizontal-axis wind turbines

J. Vilà<sup>1,4</sup>, N. Luo<sup>1</sup>, L. Pacheco<sup>3</sup>, T. Pujol<sup>2</sup>, J.R. Gonzalez<sup>2</sup>, I. Ferrer<sup>1</sup>, A. Massaguer<sup>2</sup>, E. Massaguer<sup>2</sup>

<sup>1</sup> Department of Electrical Engineering, Electronics and Automation, Polytechnic School, University of Girona, 17003 Girona (Spain)

<sup>2</sup> Department of Mechanical Engineering and Industrial Construction, Polytechnic School, University of Girona, 17003 Girona (Spain)

<sup>3</sup> Department of Computer Architecture and Technology, Polytechnic School, University of Girona, 17003 Girona (Spain)

<sup>4</sup> AULA ECOGranja Vilà, sustainable engineering, Camí Vell de Figueres a Olot S/N, Veinat de Pols, 17772 Girona (Spain)

Phone number: +34 656475276, e-mail: ningsu.luo@udg.edu

**Abstract.** The popularity of small wind turbines would rise in future, because of electricity prices are still growing. Next generation of small wind-turbines can have higher efficiency values. Under wind gusts and turbulences, the system should be very sensitive to wind conditions. In this work, it is presented a control system that can improve the performance of commercial small-scale wind turbines by including active pitch and load control. We show the electrical design of a smart active pitch control to increase the energy generation of micro-wind turbines (< 5 kWp). The electrical design controls a simple mechanism that allows the rotation of the blades by using an actuator that moves the blades according to the energy desired. The load control is also shown. These two control strategies maximise the power output at all wind conditions, and can increase the performance of small wind turbines. Moreover, important signals that allow safety actions and feedback data are monitored. The electro-mechanical design is robust and economical compare to the traditional hydraulic solution, which will increase its potential adoptability by users.

**Key words.** Electrical design, Active pitch control, Small wind turbine.

## 1. Introduction

The climate change threat demands actions towards a change of the energy model, in which self-consumption shall be promoted. Wind energy generation, however, is mainly obtained from farms that use large-scale wind turbines with power capacities exceeding the MW range. These large projects, directly connected to the network, provide returns on investment much more attractive than those of small wind turbines. However, these wind farms affect landscapes with the construction of new power transmission lines, roads, etc. In this context, important social movements fight against these changes, often promoting self-consumption alternatives such as small wind turbines. This technology had a significant expansion up to 2012 approximately, after which a continuous decline was observed [1]. The main market constraints were the zoning restrictions for the installation of these devices, high costs, almost unpredictable return on

investment analyses, and the competition of simple and reliable photovoltaic systems [1]. Thus, the small wind turbines market faces several challenges for its consolidation. It is expected that reduction of costs, certification requirements to increase product quality, and technology improvements to increase both reliability and performance will have positive impacts on this market [1]. For the latter, it is especially challenging to understand how to improve the response of the wind turbine under wind gusts [2].

Therefore, in this research, we present the electrical design of a smart control system for small horizontal-axis wind turbines as a technological advance that is required in order to favour the adoptability of small wind turbines for energy generation at micro scale [2].

The main technical disadvantage of small wind turbines corresponds to the use of fixed blades. When less than 5 kWp are considered, current state-of-the-art horizontal wind turbines include passive pitch control, but it is essentially adopted for safety purposes [3]. In terms of energy generation, an active pitch control would allow to choose the most suitable blade orientation. Such small wind turbine would even be suitable to work under intermittent and intense winds. Moreover, we propose to use electronic brake in order to keep the rotor speed under a safety range that protect the operation of the wind turbine [4]. Thus, when the wind speed is over the rated wind speed or the generator's output power exceeds the rated power, the load is modified to consume the extra electricity to keep the rotor speed under a stable situation [5]. Nowadays, the commercial implementation of active pitch control at small scales has discarded by its complexity and cost [1]. Here, we present a very simple, robust and economical system that allows to modify the pitch and load. The next sections present the mechanic and electronic system that is carried out by using low cost elements. The necessary electric system for micro and mini-wind turbines with active pitch and load control is explained. The monitoring system is also depicted.

## 2. The mechanical active pitch system

The design and analysis of the mechanical parts of the active pitch system developed for a micro-wind turbine was reported in [6]. Figure 1 shows the experimental setup where the experiments were carried out in order to validate the proof-of-concept under steady aerodynamic loads of laminar winds. Data acquired were voltage and current as a function of the load resistance instead of the rotational speed of the turbine.



Fig. 1. Prototype installed at the exit of the open-circuit wind tunnel (right of the picture) ready to be tested.

The results of output power for different resistance loads showed the validation of the active pitch system that will allow to replicate the design to mini-wind turbines (i.e., wind turbines of larger diameter and, therefore, with higher peak power capacity) that are originally built with the standard three blade design. Hence, Figure 2 depicts the output power as a function of the load resistance obtained at mean inlet wind velocities of 6 m/s. The load resistance is controlled by a potentiometer from high to low resistance with six load steps.

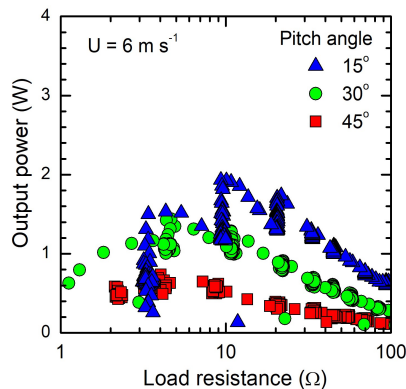

Fig. 2. Output power as a function of load resistance for different values of pitch angle. Inlet mean wind velocity equals to 6 m/s.

From Figure 2 we can see that the pitch angle has a strong influence on the extracted output power. A 15° variation (pitch angle from 15° to 30°) slightly decreases the performance -26%. However, a further 15° variation (pitch angle up to 45°) dramatically reduces the maximum output power -49%. The results show that the maximum output power at different pitch angles is achieved at different load resistance values. All the curves have different drops when the resistance load is changed by the potentiometer until it stabilises. They are specially remarked for 15° pitch angle due to the higher current generated.

## 3. Test on-field and electrical system

A cooperation agreement between Eco-farm Vilà and the Polytechnic School of the University of Girona started in 2017. Eco-farm Vilà is placed at Village of Ordís and Ordís belongs to the Alt Empordà region, where Tramuntana wind is an important source of natural energy. The main objective of the referred agreement is to improve the performance of the existing on field 2.2 kWp small horizontal-axis wind turbine. In this way, monitoring and smart control of load and active pitch are developed. Figure 3 shows the self-consumption system implemented at the Eco-farm Vilà.

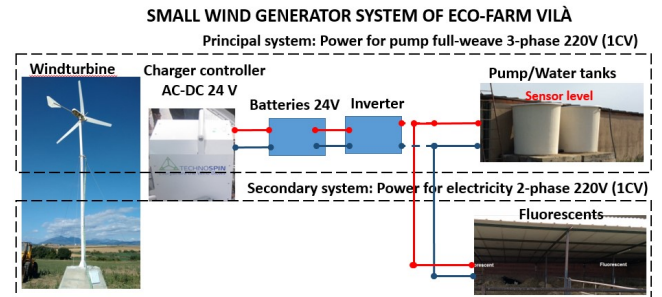

Fig. 3. Self-consumption scheme for the small horizontal axis wind turbine placed at Eco-farm Vilà.

The designed electronic system consists of a PLC (Programmable Logic Control) unit that acts as master, and three 8 bits microcontrollers units that are used as slaves, see Figure 4.

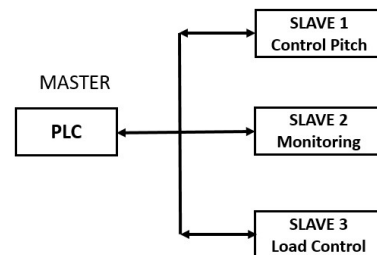

Fig. 4. Bloc diagram corresponding to different units of the electronic system developed.

The master PLC is programed for working in two different ways:

- As a master monitoring system: receive data from the slaves.
- As a master control system: can configure and give commands to the different slaves as well as read their data.

The master is connected to the three slaves by a RS485 line under MODBUS protocol. Slave 1 controls the active pitch of the system that allows to choose the most suitable blade orientation. The feedback is produced by resistor values and encoder measures. Slave 2 is used for monitoring different parameters:

- Vibrations of the generator.
- Wind forces and tensile loads on the tower structure.
- Wind speed and orientation.

Finally, slave 3 is designed for controlling and monitoring the power of the system.

#### 4. Monitoring and control electronic systems

In this section, we explain the control and monitoring electronic systems, and how the different actions are done by different slave subsystems.

##### A. Slave 1

Slave 1 controls the active pitch implementing a PID (Proportional Integral Derivative) controller that modulates a PWM (Pulse Width Modulation) signal, see Figure 5. By the mean of the PWM signal, a 24V DC (Direct Current) actuator is moved in order to achieve the desired pitch position.

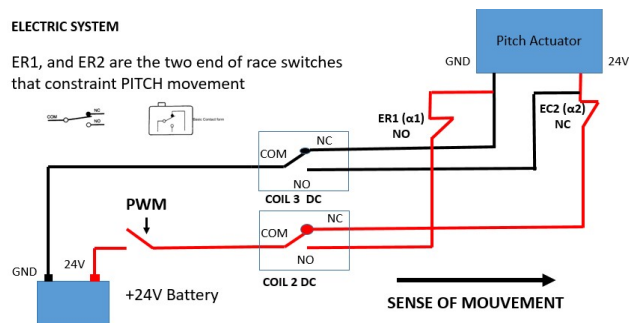

Fig. 5. Electric system for active pitch control where reverse movement is achieved using the two end of race switches, and DC motor speed is modulated by the PWM signal.

An ADC (Analog Digital Converter) is used to feedback the pitch position, which is acquired by reading the value of a linear resistor attached to the pitch displacement. The linear resistor value may be affected by the temperature value and the battery voltage. In this sense, battery level and temperature are also considered by reading an ADC signal, and digital values through I2C (Inter-Integrated Circuit) bus.

An incremental encoder provides two digital signals, A+ and A-, that are used to compute the rotor speed. The meaningful data are transmitted to the PLC when monitoring tasks are performed. The active pitch control strategy is based on the use of a LUT (Look Up Table) that selects the desired pitch position according to the turbine speed. Regarding tuning of PID parameters, a bank of memory that consists of 8 Kbytes SRAM (Static Random Access Memory) is written via I2C with the positions and speed commands when a pitch movement is performed. Moreover, using the acquired data under master PLC control mode, system identification and tuning of PID parameters can be easily done as instance if MATLAB tools are used. It is noted that when master PLC is in control mode, PID parameters or LUTs can be modified, and SRAM reading can be performed. Error check can be done in the case of mechanical or electrical failures, and it can detect failures of the motor, encoder, mechanics, or signals.

##### B. Slave 2

Slave 2 is focused on monitoring tasks such as wind speed and orientation, tower structure deformations, and

vibrations of the generator. Figure 6 shows the different elements used for implementing the monitoring tasks.

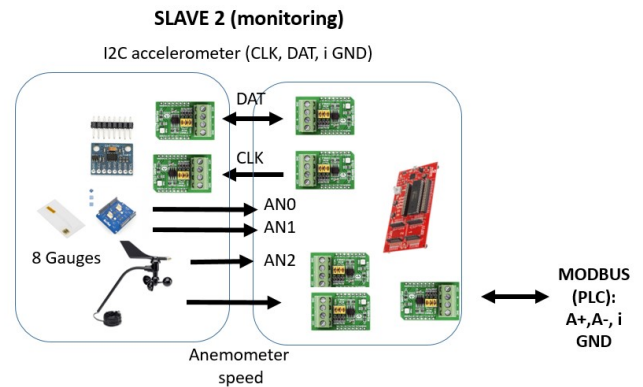

Fig. 6. Electronic devices for monitoring forces, vibrations, and wind speed and direction.

Two full bridges with 8 active gauges are used for measuring the tensile load of the tower. The objective is to measure deformation of the tower and the bending moment in order to analyze the place where cable stayed should be mounted and to compute the forces that the tower structure should support. In this way, two ADC are used for measuring the tensile loads suffered by the tower structure.

An accelerometer, placed near the generator, is used for measuring vibrations via I2C bus. Warning and alarm are produced when top limit of vibrations is overpassed, and the generator should stop because probably a blade is broken. From analog output and digital pulses of the anemometer, the orientation and speed of the wind are computed by using an ADC and digital inputs of the microcontroller. A bank of memory that consists of a 128 Kbytes SRAM is written via I2C bus with the minimal and maximum accelerations of each axis (X, Y, Z), when the wind speed is greater than a fixed threshold. It is pointed out that when master PLC is in control mode system data can be read, as instance: vibrations and tensile loads, speed and orientation of wind, SRAM data. Moreover, under master PLC in control mode, thresholds can be modified. Error check can be done looking the consistency of the data acquired by the PLC.

##### C. Slave 3

Finally Slave 3 monitors and controls the power generated, see Figure 7.

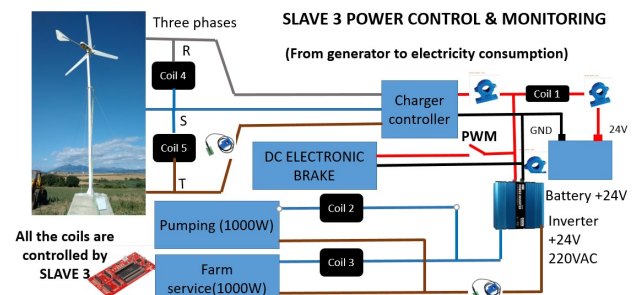

Fig. 7. Electric scheme corresponding to the power control and monitoring system implemented by slave 3.



Slave 3 uses five ADC that acquire five analog signals corresponding to two AC (Alternating Current) intensity measures, (AC output of the inverter and AC output of generator), and three DC intensity measures (output of charger, input of batteries and input of inverter). As digital inputs we consider the inputs of the tank levels (full and empty). Five digital outputs control a set of five coils that switch signals from which four are AC signals and one is DC signal. Two AC coils are used to short-cut the three-phasic output of generator, which is an action that will be done when a blade is broken or under master command when PLC is in control mode. Another two AC coils are used to select the service of pumping water or farm. When full tank is detected pumping load is not allowed. The battery level is also monitored using an ADC.

Slave 3 also controls the DC electronic brake using eight PWM signals that act on the electronic load of 2400 W. The electronic load is made using eight different modules, each one 300 W. Each module consists of a set of electric lights.

As previous slaves, Slave 3 can send the acquired data to the master PLC when monitoring system is running, and when master PLC is in control system mode the different signals can be read or the coils and configuration parameters can be modified.

Error check can be done looking the consistency of the data acquired by the PLC as the case of Slave 2.

## 5. Networks and communications

In this section, the network and communication system are explained. Figure 8 shows the block diagram corresponding to the RS485 and I2C networks used in this work.

The I2C bus implemented in this work is configured for working in multi master mode. Therefore, in this mode, the system becomes very flexible.

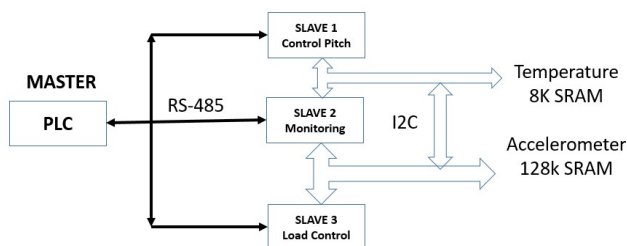

Fig. 8. Electrical design based on the use of RS485 and I2C networks.

I2C is used by Slave 1 for reading temperature sensor and reading/writing the 8K SRAM, and by Slave 2 for reading/writing the accelerometer or the 128K SRAM. Temperature and accelerometer sensors and SRAM memories are configured as I2C slaves. However, Slaves 1, 2 and 3 are configured as masters when I2C is considered. The fact of considering Slaves 1, 2 and 3 as masters allows the possibility of communication between them. Consequently, when high vibrations are detected or rotor speed is too large, the power system can be

controlled according to safety criteria. The flexibility of the multi master I2C network proposed may allow the system to work without the need of PLC.

The RS-485 network was introduced in Section 3 because it is the backbone of this proposal. It allows the PLC to work in two modes (monitoring and control). Figure 9 summarizes the signals used in this work.

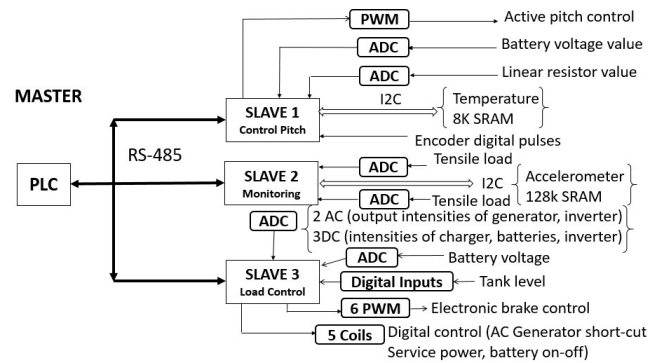

Fig. 9. Different signals that can be controlled or monitored by PLC using the RS-485 communication line.

The RS-485 works under MODBUS protocol. Under monitor mode the PLC read the meaningful data acquired by the slaves. When PLC is in control mode, reading or writing can be done in any parameter of slaves.

## 6. Conclusions

We have designed a complete electronic system that allows smart control and monitoring for a horizontal-axis micro-wind turbine with the purposes of increasing its performance and of making the device more robust against gust and high winds. The main control system consists in the combination of an active pitch control and an electronic brake that reduces the generator speed by increasing the electric load. The proposed design is simple, robust and economical. The sensors and boards used in this work are explained as a need of the control system in order to make it smart. Wind gust and turbulences are strongly related to territory and characterize the different regions. In this context, it is proposed a low cost flexible system suitable to be used under different wind conditions. Fundamental issues of a horizontal axis micro wind turbine as power control and tower structure are analysed. From the data monitored by PLC, it is expected to improve the parameter adjustments and consequently the power acquired. In this way, this technology applied to mini-wind turbines seems to be a feasible candidate to improve the performance from current devices.

## Acknowledgement

This work has been cofunded by the European Union through the European Regional Development Funds (FEDER). It has also been cofunded by the Secretaria d'Universitats i Recerca del Departament d'Empresa i Coneixement de la Generalitat de Catalunya through the Agència de Gestió d'Ajuts Universitaris i de Recerca

under contract Ajut Llabor - 2019 LLAV 00003. Aula Ecogranja Vilà also supported the project.

The authors appreciate the final year project developed by Adrià Quintana, Pol Carreras and Jose Angel Alcaide that make possible the implementation of this research.

## References

[1] C.C.M Chagas, M.G. Pereira, LP. Rosa, N.F. da Silva, M.A. Freitas and J.D Hunt, "From megawatts to kilowatts: A review of small wind turbine applications, lessons from the US to Brazil", *Sustainability* (2020). Vol. 12(7), pp 2760.

[2] A. Tummala, R.K. Velamati, D.K. Sinha, V. Indraja and V.H. Krishna, "A review on small scale wind turbines", *Renewable and Sustainable Energy Reviews* (2016). Vol. 56, pp.1351-1371.

[3] Enair Energy. Visited the 8 of February of 2022: <https://www.enair.es/es/>

[4] D. Adams, J. White, M. Rumsey and C. Farrar, "Structural health monitoring of wind turbines: method and application to a HAWT" *Wind Energy* (2011). Vol. 14(4), pp. 603-623.

[5] Aeolos Wind Energy Ltd. Visited the 8 of February of 2022: <https://www.windturbinestar.com/small-wind-turbine-safety.html>.

[6] J. Vilà, N. Luo, L. Pacheco, T. Pujol, J.R. Gonzalez, I. Ferrer, A. Massaguer, E. Massaguer, "Design of an active pitch control for small horizontal-axis wind turbine", *Renewable Energy and Power Quality Journal*, (2021). Vol. 19, pp. 195-198.